



# Energy Efficiency and Historic Buildings

## Draught-proofing windows and doors



This guidance note is one of a series which explain ways of improving the energy efficiency of roofs, walls and floors in historic buildings. The full range of guidance is available from the English Heritage website:

[www.english-heritage.org.uk/partL](http://www.english-heritage.org.uk/partL)

# Introduction to the series

This guidance note is one of a series of thirteen documents providing advice on the principles, risks, materials and methods for improving the energy efficiency of various building elements such as roofs, walls and floors in older buildings. The complete series includes the following publications:

## ROOFS

*Insulating pitched roofs at rafter level/warm roofs*  
*Insulating pitched roofs at ceiling level/cold roofs*  
*Insulating flat roofs*  
*Insulating thatched roofs*  
*Open fires, chimneys and flues*  
*Insulating dormer windows*

## WALLS

*Insulating timber framed walls*  
*Insulating solid walls*  
*Early cavity walls*

## WINDOWS AND DOORS

*Draught-proofing windows and doors*  
*Secondary glazing*

## FLOORS

*Insulation of suspended ground floors*  
*Insulating solid ground floors*

All these documents can be downloaded free from:  
[www.english-heritage.org.uk/partL](http://www.english-heritage.org.uk/partL)

This series of guidance documents provide more detailed information to support our principle publication:

*Energy Efficiency and Historic Buildings: Application of Part L of the Building Regulations to historic and traditionally constructed buildings*

This publication has been produced to help prevent conflicts between the energy efficiency requirements in Part L of the Building Regulations and the conservation of historic and traditionally constructed buildings. Much of the advice is also relevant where thermal upgrading is planned without the specific need to comply with these regulations.

The advice acts a 'second tier' supporting guidance in the interpretation of the Building Regulations that should be taken into account when determining appropriate energy performance standards for works to historic buildings.



---

## CONSERVATION PLANNING

Before contemplating measures to enhance the thermal performance of a historic building it is important to assess the building and its users to understand:

- the heritage values (significance) of the building
- the construction and condition of the building fabric and building services
- the existing hygrothermal behaviour of the building
- the likely effectiveness and value for money of measures to improve energy performance
- the impact of the measures on heritage values
- the technical risks associated with the measures

This will help to identify the measures best suited to an individual building or household, taking behaviour into consideration as well as the building envelope and services

---

## TECHNICAL RISKS POSED BY THERMAL UPGRADING OF OLDER BUILDINGS

Altering the thermal performance of older buildings is not without risks. The most significant risk is that of creating condensation which can be on the surface of a building component or between layers of the building fabric, which is referred to as 'interstitial condensation'. Condensation can give rise to health problems for occupants as it can lead to mould forming and it can also damage the building fabric through decay. Avoiding the risk of condensation can be complex as a wide range of variables come into play.

Where advice is given in this series of guidance notes on adding insulation into existing permeable construction we generally consider that insulation which has hygroscopic properties is used as this offers a beneficial 'buffering' effect during fluctuations in temperature and vapour pressure, thus reducing the risk of surface and interstitial condensation occurring. However, high levels of humidity can still pose problems even when the insulation is hygroscopic. Insulation materials with low permeability are not entirely incompatible with older construction but careful thought needs to be given to reducing levels of water vapour moving through such construction either by means of ventilated cavities or through vapour control layers.

The movement of water vapour through parts of the construction is a key issue when considering thermal upgrading but many other factors need to be considered to arrive at an optimum solution such as heating regimes and the orientation and exposure of the particular building.

More research is needed to help us fully understand the passage of moisture through buildings and how certain forms of construction and materials can mitigate these risks. For older buildings though there is no 'one size fits all' solution, each building needs to be considered and an optimum solution devised.

---

## TECHNICAL ILLUSTRATIONS GENERALLY

The technical drawings included in this guidance document are diagrammatic only and are used to illustrate general principles. They are not intended to be used as drawings for purposes of construction.

Older buildings need to be evaluated individually to assess the most suitable form of construction based on a wide variety of possible variables.

English Heritage does not accept liability for loss or damage arising from the use of this information.

# Content

---

Introduction 05

---

**01** Repairing windows and doors 06

---

**02** Draught-proofing rather than double glazing 11

---

**03** Issues to consider before draught-proofing 12

---

**04** Draught-proofing and the Building Regulations 14

---

**05** Draught-proofing products 14

---

**06** Further information 20

---

English Heritage Local Offices 21

---

# Introduction

This guidance note provides advice on the principles, risks, materials and methods for improving the thermal performance of existing windows and doors by draught-proofing.

Draught-proofing is one of the most cost effective and least intrusive ways of improving the comfort of occupants and reducing energy used for heating with little or no change to a building's appearance. It has the added benefit of helping to reduce noise and keeping out dust. Recent research has shown draught-proofing can reduce air leakage in windows by between 33% and 50% significantly reducing the energy requirement needed for heating the room.

Windows and doors of the original pattern and material make a major contribution to the character of historic buildings and every effort should be made to retain them rather than replace them. Windows and doors can tell us a lot about the history of a building; changing architectural taste and style, social hierarchy, building economics, craft skills and technical advances. Windows in particular are often a key element which establishes the character of a building and often the character of a neighbourhood.

Older buildings are prone to heat loss through cracks and gaps which develop as various building elements move and distort over a long period. This is often the case for windows and doors which can be a major source of heat loss. Less than a quarter of the heat lost through a typical traditional window escapes by conduction through the glass, the rest is by draughts (air infiltration). Since draughts make people feel colder, the occupants often turn up the heating and run it for longer.

Windows and doors should be assessed for repairs before embarking on any draught-proofing measures. Traditional windows and doors can almost always be improved by being repaired, even if they are in very poor condition.

# 01 Repairing windows and doors

---

## NEED TO REPAIR

All types of windows will decay over time, so regular inspection and maintenance will always be a good investment. Before installing any draught-proofing to windows or doors, it makes sense to identify and make any repairs that are needed first. Straight-forward repairs can reduce air infiltration and heat loss by up to a third.

Many old buildings have changed shape gradually over a long period owing to settlement and thermal movement. Old buildings can tolerate a surprising amount of movement so that windows and doors may have gradually adjusted to suit this re-alignment. Often the window sashes hold their shape better than their frames resulting in gaps and sashes sticking within the frame.

---

## REPAIR OR REPLACE?

Traditional timber and metal windows and doors can almost always be repaired usually at a cost significantly less than replacement. Repaired originals will also have character and historic value which a replica window would not have. Total replacement of a window or a door even as an exact replica may require consent if the building is listed.

Historic glass should be retained in any programme of repair. Modern glass is made by a float process that produces precisely flat, optically perfect glass. Historic glass, which was produced by one of several different processes, has a completely different character. The imperfections in hand-made glass are a feature that makes many older windows so attractive.



01 Historic glass should be retained in any programme of repair © Clive Murgatroyd

---

## LOOSENING STUCK WINDOWS

Windows that are firmly stuck in place may have assumed a structural role and be taking the weight of the wall above. This is usually because a lintel above has failed or moved. They should not be forced open as they might break and it has been known for parts of a wall to collapse when windows are opened. First assess what is happening structurally. If there is any doubt, insert props into the window frame before attempting to open them.

Particular care should be taken when removing a window frame for repairs. Even where the window is still operable, its frame may carry some structural loads. Some early 20th century bay windows were specifically designed to be structural.

Windows that are painted shut should be opened carefully, using sharp knives and only gentle pressure. Some windows and doors may have been discreetly nailed or screwed closed – these should be checked before using force.

---

## PREPARING TO REPAIR

Before windows are removed for repair they should be carefully recorded, at least with photographs and some basic measurements. Sashes, casements and other parts should be labelled to ensure that they go back in the correct positions. Before stripping many layers of accumulated paint, think about having a paint analysis. This might reveal information about the previous colour schemes which could inspire future paint schemes. If possible consider leaving a small section of existing paint layers in situ for future analysis.

The use of glazed external protection for windows using either glass or plastic sheet is referred to as 'storm glazing' or 'isothermal glazing' rather than secondary glazing. This method is often used to protect stained glass in churches. With this system it is important to understand the potential conditions this creates in the airspace between the existing glazing and the additional external glazing where ventilation will be required. Account should also be taken of the environmental conditions inside the building before designing the installation. One option is to install storm glazing in the winter months and remove it in the summer months.

Traditional timber and metal windows can almost always be repaired, even when in quite poor condition and normally at significantly less cost than complete replacement. The timber used in the past to make windows was of a high quality and very durable. Many Georgian and Victorian windows are still in place today whereas modern windows can need replacement after only 20 years. Repairing windows is the best way of maintaining the visual character and architectural significance of a building's elevation and can add to its value.

Before starting any upgrading work such as draught-stripping or the addition of secondary glazing, assess what repairs are needed to make the windows fully operational. Windows decay over time so regular maintenance, cleaning and painting is always a good investment.

For listed buildings, the total replacement of a window is likely to require Listed Building Consent.

## LEAD PAINT

Lead paints can be harmful to health, particularly for children.

Lead based paints are often found on older buildings. Sometimes these paints have been over-painted. If there is any uncertainty about the presence of lead paint on windows that are to be stripped, it should be assumed that lead paint is present and precautions taken accordingly.

The use of lead paints has now been generally banned because of the hazard to health. However, there is an exception to the ban which allows them to be used on Grade I and Grade II\* listed buildings. On those buildings the traditional appearance of the lead paint, together with its longevity and its fungicidal and insecticidal properties, mean that it is often still used. It should only be applied by professional decorators using appropriate protective equipment, and it is not recommended for use where it may be in the reach of children.



**02/03** Before installing any draught-proofing to windows identify and make any repairs that are needed first.  
© English Heritage/Chris Wood/Robyn Pender

---

## REPAIRING WOOD WINDOWS AND DOORS

The base of doors and their frames are particularly susceptible to wet rot as are the lower horizontal rails and sills of windows but such decay can be repaired using carpentry techniques. Repairs will usually be weaker than the original joint and repaired sections may also expand and contract at slightly different rates, putting strain on the junctions and leading to cracks which may then foster further decay. Regular maintenance of repaired windows is particularly important.

The approach to the repair will depend upon the extent of the decay, the performance requirements, and the significance of the original material. If a window or door is historically or visually important, and not likely to be subject to heavy wear and tear, it is usually best to keep as much as possible of the original material and splice in sections of new timber. Where a decayed window or door is in poor condition and not particularly important historically, it may be appropriate and more economic to replicate it completely in carefully selected, good quality new timber, perhaps salvaging just the glass if this is of historic interest. The decision will depend on how effective and long-lasting the repair is likely to be. Repairs using epoxy resin can in many cases be used alongside carpentry repairs to prolong the life of doors and windows.



## PAINT ANALYSIS

Many surfaces in historic buildings have been over-coated many times during their history without stripping of the layers beneath. These layers form an important archaeological record.

Often a fragment of the surface coatings can be removed containing all of the accumulated layers. This composite piece can be sent away for analysis in a specialist laboratory, where each of the layers can be revealed by analysing the material and colour of each layer. This can reveal a wealth of information about the history and presentation of the building. In the past these techniques have led to the discovery of hidden wall paintings beneath plain surfaces. More frequently they provide the evidence to justify a change in presentation of the outside of a building from a modern paint scheme to a traditional scheme which has proven historical precedent.

Fragments of coatings sent for analysis need only be very small and should only be taken from an inconspicuous section of the window or door door.

---

## REPAIRING METAL WINDOWS

Metal windows can suffer from surface rust, distortion, excessive build-up of paint, and failed hinges and fittings. Rust expands up to seven times the volume of un-oxidised metal, so corrosion often looks much worse than it really is. Even windows which appear in a very bad state at first sight can usually be repaired.

Rust and paint can be removed by acid pickling or flame cleaning. Firms specialising in this are found in most towns. Any necessary repairs to wrought iron or steel windows can be made by a metalworker welding in replacement sections. Cast iron windows cannot be welded because they tend to crack when heated, but they can be repaired using a technique known as 'cold stitching'.



**04** Metal windows can suffer from surface rust, distortion and excessive build up of paint but they are capable of repair.  
© English Heritage/ David Pickles

---

## REPAIRING LEADED LIGHT WINDOWS

Leaded light windows are found in buildings from many periods. Their repair is a specialist task and should be approached with caution, particularly if the windows are old. A list of specialist contractors can be obtained from ICON (see Further Information). It may not be sensible even to attempt to repair leaded light windows to draught-free levels, but sometimes internal or external secondary glazing can be added to provide protection and draught-proofing.



**05** Leaded light windows can be difficult to make draught free and secondary glazing might need to be considered.  
© Oxley Conservation

## 02 Draught-proofing rather than double glazing

---

Double glazed windows usually have sealed glazing units with two panes of glass separated by an air gap (typically of 12-18 mm) which improves thermal insulation, particularly if the glass is coated and the air gap is filled with an inert gas. It is an important development that has produced significant energy savings and reductions in carbon dioxide emissions, particularly in new buildings. The Building Regulations make double glazing practically compulsory in new building.

The replacement of existing windows with double glazed units can in many cases lead to a change in appearance, particularly the flatness of new glass and the need for thicker timber sections and glazing bars. The additional weight of glass (up to four times more than the weight of single glazing) and the balancing of the opening sashes pose added problems.

In historic buildings, there should be a strong preference for repair rather than replacement as the use of double glazing will inevitably lead to a loss of historic fabric. Adding secondary glazing would often be the preferred option.

The benefits of double glazing over other methods of window repair are often over-estimated. Much of the comfort and energy efficiency benefits of new double glazing come from the reduction of draughts that will result from well-fitted window frames with integral draught-proofing. These benefits are also available through repair and draught-proofing of the existing windows, or from fitting secondary glazing.

In terms of noise reduction, double glazed units can be no better than single glazed units; and can be slightly worse for traffic noise. The important criteria for noise reduction are that the windows are well fitted and draught-proofed. Secondary glazing, with its larger gap (ideally 100 mm) between the panes, is a better sound insulator. Shutters and heavy curtains also work well.

## 03 Issues to consider before draught-proofing

Before embarking on draught-proofing a whole building, it is sensible to identify the extent of draughts and where they enter. A fan pressurisation test is the most effective way of quantifying the amount of air infiltration and locating draughts that may not be immediately evident (via cupboards, ducts and skirting and window boards). Temporarily taping around the windows during the test can show how much they leak. Smoke puffers can also show how big the draughts are and where they go. If the tests are repeated after draught-proofing has been carried out this will confirm its effectiveness and may highlight any areas missed.



**06** A fan pressurisation test is the most effective way of quantifying the amount of air infiltration and locating draughts that may not be immediately evident © Oxley Conservation

## QUANTIFYING DRAUGHTINESS

The draughtiness of a building depends upon the amount of air that can pass through its external envelope – walls, floor and roof. This is referred to as the air permeability. The industry standard is to express the permeability of a wall, roof, or whole building envelope assuming a pressure difference of 50 Pascals across the wall. The permeability is then measured as the amount of air (in cubic metres) that will pass in an hour through a square metre of wall (or roof, or floor) and expressed as m<sup>3</sup>/h/m<sup>2</sup> (m<sup>3</sup>/hm<sup>2</sup> or m/h) at a pressure difference of 50 Pascals (50 Pa).

While permeability is what causes draughtiness and ventilation, what is more important for the building and its occupants is the rate at which air moves through the building. This is most simply measured as the number of times that the air in the building changes each hour (written “ac/h” or sometimes “ach”). Again this will depend upon the pressure difference between the outside and the inside of the building, and again the industry standard is to assume a pressure difference of 50 Pa.

The relationship between these two measures is given by the following formula:

$$\frac{\text{Air changes per hour} = \text{Permeability} \times \text{external surface area of building}}{\text{Internal volume of building}}$$

The conversion from air changes per hour at 50 Pa to air changes per hours under normal conditions (around 4 Pa) is complex, depending upon the location of the building, its orientation and its geometry. A very approximate rule of thumb is to divide the ac/h @50Pa by 20 to obtain ac/h (typical).

---

## MAINTAINING VENTILATION

Some degree of ventilation is essential for the fabric of older buildings which need to ‘breathe’ – releasing and absorbing moisture. Moisture from rising damp, driving rain, defects and condensation can move through traditional permeable building materials until it eventually evaporates both internally and externally through permeable surface finishes. Ventilation is critical to this mechanism. Whilst draught-proofing reduces air infiltration, older buildings can tolerate some draught-proofing and still have adequate ventilation for the fabric to continue to breathe satisfactorily.

In rooms being used for living and sleeping about 0.4 air changes per hour will be enough to ensure that the air stays fresh. Ideally some of this ventilation should be from controllable sources that can be closed when the rooms are not in use. New construction is often built to be as airtight as possible with controllable mechanical ventilation sometimes linked with heat recovery systems. Retrofitting mechanical ventilation systems into existing buildings can be very difficult, and potentially damaging.

For older buildings in reasonable condition, between 0.4 and 0.8 air changes per hour are recommended. Since air infiltration rates in many older buildings are greater than this, draught-proofing is normally beneficial.

In buildings that are effectively draught-proofed, water vapour may also need to be removed at source – particularly from kitchens, bathrooms and laundries – so that the vapour is not spread about the building. Some local air extraction (natural or mechanical) may be required in these areas.

Special care should be taken in rooms with open fires or other combustion appliances, to avoid depriving them of sufficient air. Specialist advice should be sought before sealing any rooms containing gas or oil burning appliances.

Unheated spaces, such as roof and sub-floor voids, are often designed to be cross-ventilated by outside air and should not be draught-proofed. Damp cellars may not benefit from draught-proofing either.

## 04 Draught-proofing and the Building Regulations

---

Standards for air-tightness for new buildings are wide-ranging in scope and apply to the whole building and not just for individual elements. There are no specific requirements for draught-proofing existing buildings, but Building Regulations will apply if:

- the doors or windows are beyond repair and there is no alternative to replacement

or

- the building is undergoing a 'change of use'.

Where Building Regulations do apply, a dialogue will probably be required between the local authority Building Control Officer or Approved Inspector and the Conservation Officer to agree what works would be acceptable and what would require permission. Upgrading existing windows by adding effective draught-proofing, or where new windows are required, replicating the historically/architecturally important single glazed windows enhanced by draught-proofing, might form part of a compromise reached to improve the energy efficiency of a traditional building whilst retaining its historic significance.

## 05 Draught-proofing products

---

This guidance describes generic draught-proofing products and how they can be used. Always check against the manufacturer's own instructions to be sure that the product is suitable for the application. Choosing the right products for draught-proofing can be difficult. When windows and doors are often distorted many products will not work effectively as they can only deal with a specific range of gap widths. Some products are also applied to the surface of a door or window frame, while concealed solutions are generally more suited to historic buildings.

When choosing a draught –proofing product the following should be considered:

- how big are the gaps to be sealed?
- how variable is the width of the gaps?
- does allowance need to be made for seasonal expansion and contraction of the door or window?
- is it important that the draught-strip is not seen? What about when the window is open?
- does the draught-strip need to match the colour of the frame? Painting the flexible part of a seal is not recommended as it changes the characteristic of the product.
- will the draught-strip be renewed every time the door or window is redecorated? If not, it will either need to be capable of being removed and reinstalled after decoration.

There is a British Standard (BS7386) which covers the quality of draught-proofing products. Specifying and purchasing products that meet that benchmark will help ensure minimum standards are met.

There are two main types of draught-proofing seals:

- compression seals
- wiper seals.

*Example of draughtproofing for sash windows*

*Typical draught seal profiles*

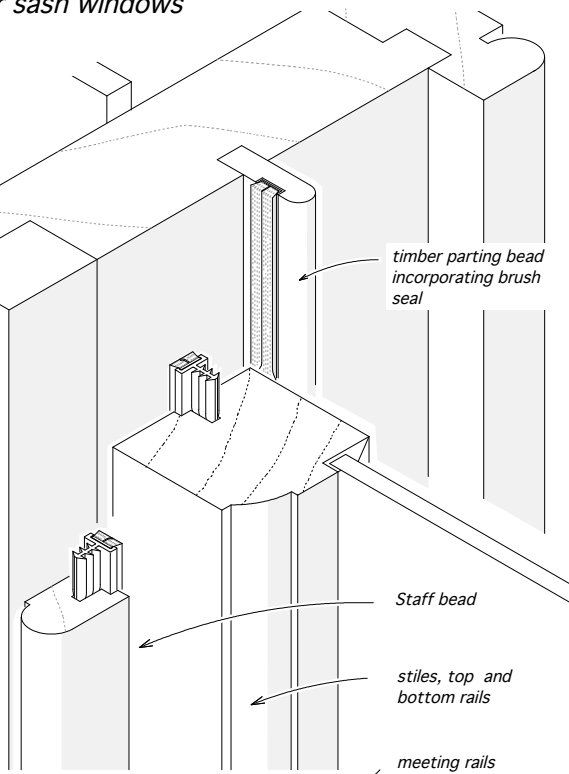
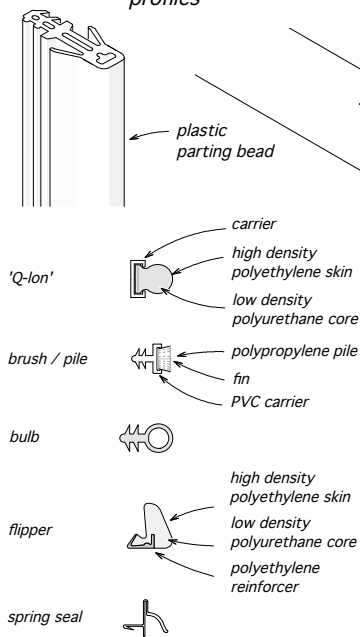

*Examples of draughtproofing for casements or doors*

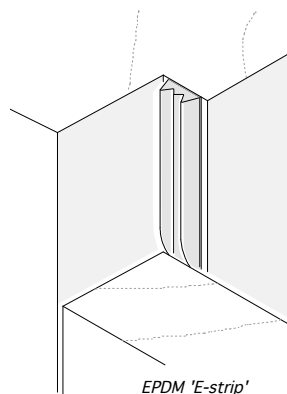
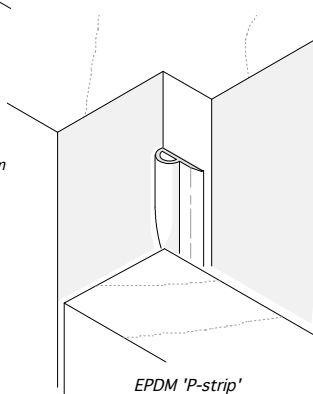
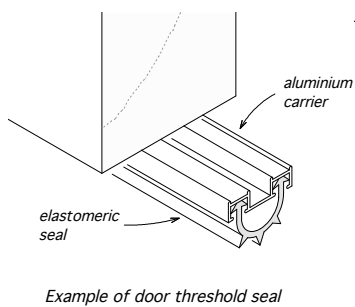
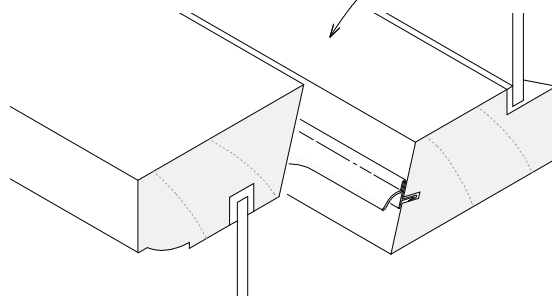
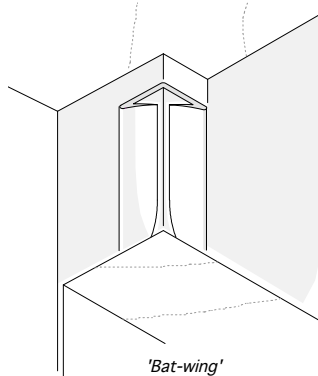

---

## COMPRESSION SEALS

### APPLICATIONS

Compression seals are used where the moving part of the door or window closes against the frame. Typical applications include around the sides and top of a door or around the entire edge of a casement window. Compression seals can also be used along the bottom and top rails of a sash window.

Compression seals are usually quite cheap and easy to install. They are most appropriate for sealing narrow, even gaps. They require some compression to be effective, but cannot be compressed too far, so a given size of seal therefore only works on a narrow range of gaps. This makes them difficult to fit to casements and doors with some warping because of the variation in gap thickness.

Since compression seals are typically mounted to abut the face of a casement or door they are relatively unaffected by the effect of seasonal expansion and contraction of doors and windows.

### MATERIALS

Compression strips are available in a range of materials. The simplest to install are self adhesive strips of EDPM rubber. These are available in a variety of profiles and thicknesses to cater for different gap widths. Foam strips are cheaper still but have a short life.

Silicone and EDPM “O” tubes are available in a variety of diameters. Some attach to the frame using an adhesive others come on a carrier strip that is either attached to or cut into the frame.

V-shaped silicone and EDPM seals are an alternative that can bridge a greater range of gap sizes.

Silicone is taking over from EDPM as the material of choice for compression strips because it is available in a range of colours, including white. Brush pile seals, more typically used as wiper seals and described below, can also be used as compression seals.

For metal windows, particularly those with irregular gaps, a silicone gel or polymerised rubber can be used to create a compression seal. The gel is applied from a tube onto the frame. Non-stick tape or more usually grease is applied to the meeting surfaces of the window, which is then immediately closed to squeeze the sealant into a perfect fit. When the sealant is dry (a few minutes), the window is opened, the seal trimmed, and the release tape or grease removed.



---

## WIPER SEALS

These are used when the moving parts slide past each other.



**08** Brush pile seals can be inserted into window and door beads © Core sash windows



**10** A brush pile seal being inserted into a window sash © Core sash windows



**09** Brush pile seals added to a sash window © English Heritage/David Pickles

### APPLICATIONS

Wiper seals are the only way of sealing the sides and meeting rails of sliding sash windows and sliding doors.

Wiper seals can also be fitted to the edges of casement windows or doors. Here they can still work, even when the window or door is moderately warped.

Wiper seals are frequently used at the base of doors where they are attached to the face of the door. Door threshold seals are also available that fix to a groove in the door and/or the threshold beneath the door. These require a relatively even gap and a smooth surface to make a good seal.

### MATERIALS

The most common wiper seals are brush pile seals. These are capable of sealing a range of gap sizes, and adapt to fill uneven gaps well. Some include a thin plastic fin or fins in the centre to make a better seal.

Other wiper seals are made of silicone or thermoplastic strips where a heavy duty seal is needed. V-strip wiper seals are also available, and can be used between the stiles and boxes of sliding sashes.

Some wiper seals are supplied with a simple backing strip for gluing or pinning to a window frame. Others require a narrow groove cut into the wood into which the base of the seal is pushed.

---

## SECONDARY GLAZING

Secondary glazing is sometimes chosen more for its draught-proofing qualities than for thermal and noise insulation; particularly where other solutions are not feasible, for example when gaps are too large to seal, the windows are too significant to alter, or to protect stained glass. If secondary glazing is installed, the original windows should not be draught-proofed to help avoid condensation occurring.



**||** Secondary glazing can provide very effective draught-proofing as well as improved thermal efficiency  
© English Heritage/David Pickles

---

## DRAUGHT-PROOFING SHUTTERS

Shutters can also be draught-stripped using the same products as above. This will minimise the heat loss when the shutters are closed, usually at night. However this is of limited benefit:

- draught-proofed shutters will add little benefit to draught-proofed windows. As the windows will be closed more often than the shutters, the windows should receive priority.
- shutters spend much of their time folded back, and are often visible when they are not in use. Visible shutters are frequently important to the look of the exterior or interior of the building. It is difficult to hide a draught-strip in both the open and closed positions.
- many shutters were designed to control light and privacy, not heat loss, for example to darken rooms for sleeping, to reduce solar gain in summer, or to protect delicate contents from ultra-violet light. Some have holes to allow ventilation when closed.



**12** Shutters can be draught-stripped which will minimise heat loss when the shutters are closed at night © Linda Hall

# 06 Further information

---

British Standards Institution 2011, *Code of Practice for control of condensation in buildings* BS 5250, London: British Standards Institution

British Standards Institution: 1997 *Specification for draughtstrips for the draught control of existing doors and windows in housing*. (BS7386) British Standards Institution

British Standards Institution 1997: *Code of Practice for draught control of existing doors and windows in housing using draughtstrips* (BS7880) British Standards Institution

British Standards Institution 1976 *Methods for testing windows for air permeability* (BS5368-1) British Standards Institution

English Heritage, 2009, *Improving the thermal performance of traditional windows*, English Heritage. London

English Heritage, 2012, *Practical Building Conservation: Timber*, Ashgate

English Heritage, 2012, *Practical Building Conservation: Glass and Glazing*, Ashgate

Georgian Group, (n.d.) *Georgian Windows: A brief guide to the History and Replacement of Windows in Georgian Buildings*; The Georgian Group.

Historic Scotland; 2008, *Technical Paper 1, The Thermal Performance of Traditional Windows*; Historic Scotland

Tutton, Hurst, Pearce (eds); 2007 *Windows: history, repair and conservation*; Donhead;

Townsend, A. and Clarke, M.1998 *The Repair of Wood Windows, Technical Pamphlet 13*, Society for the Protection of Ancient Buildings, London

Victorian Society, 1999, *Timber Windows: No. 9 in the Care for Victorian Houses Series*; The Victorian Society.

---

## ADVISORY BODIES

Draught Proofing Advisory Association Limited  
PO Box 12, Haslemere, Surrey GU27 3AH  
Tel: +44 (0)1428 654011  
Fax: +44 (0)1428 651401

# English Heritage Local Offices

---

## **NORTH EAST**

English Heritage  
Bessie Surtees House  
41 - 44 Sandhill  
Newcastle upon Tyne  
NE1 3JF  
Tel: 0191 269 1200  
E-mail: [northeast@english-heritage.org.uk](mailto:northeast@english-heritage.org.uk)

## **NORTH WEST**

English Heritage  
3rd floor Canada House  
3 Chepstow Street  
Manchester  
M1 5FW  
Tel: 0161 242 1400  
E-mail: [northwest@english-heritage.org.uk](mailto:northwest@english-heritage.org.uk)

## **YORKSHIRE AND THE HUMBER**

English Heritage  
37 Tanner Row  
York  
YO1 6WP  
Tel: 01904 601901  
E-mail: [yorkshire@english-heritage.org.uk](mailto:yorkshire@english-heritage.org.uk)

## **WEST MIDLANDS**

English Heritage  
The Axis  
10 Holliday Street  
Birmingham  
B1 1TG  
Tel: 0121 625 6820  
E-mail: [westmidlands@english-heritage.org.uk](mailto:westmidlands@english-heritage.org.uk)

## **EAST MIDLANDS**

English Heritage  
44 Derngate  
Northampton  
NN1 1UH  
Tel: 01604 735400  
E-mail: [eastmidlands@english-heritage.org.uk](mailto:eastmidlands@english-heritage.org.uk)

## **EAST OF ENGLAND**

English Heritage  
Brooklands  
24 Brooklands Avenue  
Cambridge  
CB2 8BU  
Tel: 01223 582700  
E-mail: [eastofengland@english-heritage.org.uk](mailto:eastofengland@english-heritage.org.uk)

## **LONDON**

English Heritage  
1 Waterhouse Square  
138 - 142 Holborn  
London  
EC1N 2ST  
Tel: 020 7973 3000  
E-mail: [london@english-heritage.org.uk](mailto:london@english-heritage.org.uk)

## **SOUTH WEST**

English Heritage  
29 Queen Square  
Bristol  
BS1 4ND  
Tel: 0117 975 0700  
E-mail: [southwest@english-heritage.org.uk](mailto:southwest@english-heritage.org.uk)

## **SOUTH EAST**

English Heritage  
Eastgate Court  
195-205 High Street  
Guildford  
GU1 3EH  
Tel: 01483 252000  
E-mail: [southeast@english-heritage.org.uk](mailto:southeast@english-heritage.org.uk)

## **CONSERVATION DEPARTMENT**

English Heritage  
The Engine House  
Fire Fly Avenue  
Swindon  
SN2 2EH  
Tel: 01793 414963  
E-mail: [conservation@english-heritage.org.uk](mailto:conservation@english-heritage.org.uk)

---

English Heritage is the Government's statutory adviser on the historic environment. English Heritage provides expert advice to the Government about all matters relating to the historic environment and its conservation.

The Conservation Department promotes standards, provides specialist technical services and strategic leadership on all aspects of the repair, maintenance and management of the historic environment and its landscape.

This guidance has been prepared on behalf of English Heritage by Oxley Conservation under the direction of Phil Ogle and has been edited by David Pickles, Ian Brocklebank and Chris Wood

First published by English Heritage, September 2010.

This edition published March 2012

Product code: 51680

[www.english-heritage.org.uk](http://www.english-heritage.org.uk)

---

If you would like this document in a different format,  
please contact our Customer Services Department:

Telephone: 0870 333 1181

Fax: 01793 414926

Textphone: 01793 414878

E-mail: [customers@english-heritage.org.uk](mailto:customers@english-heritage.org.uk)



ENGLISH HERITAGE